

YALÇIN GOLD BATTERY

YGL12055.0 (12V55AH)

Specification

Nominal Voltage	12V	
Nominal Capacity(10HR)	55.0AH	
Dimension	Length	229±3mm (9.02 inches)
	Width	138±2mm (5.43 inches)
	Container Height	210±3mm (8.27 inches)
	Total Height (with Terminal)	230±3mm (9.06 inches)
Approx Weight	Approx 17.7 Kg (39.0 lbs)	
Terminal	T9	
Container Material	ABS	
Rated Capacity	58.8 AH/2.94A	(20hr ,1.80V/cell,25 °C/77 F)
	55.0 AH/5.50A	(10hr,1.80V/cell,25 °C/77 F)
	47.9 AH/9.57A	(5hr,1.75V/cell,25 °C/77 F)
	42.9 AH/14.3A	(3hr,1.75V/cell,25 °C/77 F)
	34.1 AH/34.1A	(1hr,1.60V/cell,25 °C/77 F)
Max. Discharge Current	660A (5s)	
Internal Resistance	Approx 7.5mΩ	
Operating Temp.Range	Discharge	-15~50°C (5~122°F)
	Charge	0~40°C (32~104°F)
	Storage	-15~40°C (5~104°F)
Nominal Operating Temp. Range	25±3°C (77±5°F)	
Cycle Use	Initial Charging Current less than16.5A.Voltage	
	14.4V~15.0V at 25°C(77°F)Temp. Coefficient -30mV/°C	
Standby Use	No limit on Initial Charging Current Voltage	
	13.5V~13.8V at 25°C(77°F)Temp. Coefficient -20mV/°C	
Capacity affected by Temperature	40°C (104°F)	103%
	25°C (77°F)	100%
	0°C (32°F)	86%
Self Discharge	Yalcin Gold series batteries may be stored for up to 6 months at 25°C(77°F) and then a freshening charge is required. For higher temperatures the time interval will be shorter.	

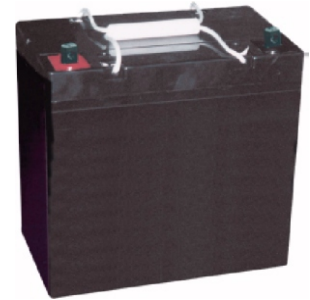

Applications

- ◆ UPS and EPS
- ◆ Emergency light
- ◆ Railway signal and aircraft signal system
- ◆ Marine and power stations Alarm and security system
- ◆ Electronic apparatus and equipment
- ◆ Communication power supply, DC power supply

Constant Current Discharge (Amperes) at 25 °C (77°F)

F.V/Time	10min	15min	20min	30min	45min	1h	2h	3h	4h	5h	6h	8h	10h	20h
1.85V/cell	64.4	54.1	48.0	39.8	30.7	26.3	17.0	12.8	10.5	8.82	7.73	6.20	5.33	2.84
1.80V/cell	73.6	60.8	53.1	43.3	33.1	27.8	18.3	13.8	11.1	9.35	8.19	6.52	5.50	2.94
1.75V/cell	83.6	68.5	58.7	47.0	36.2	30.3	19.0	14.3	11.5	9.57	8.44	6.74	5.65	3.02
1.70V/cell	94.5	76.0	64.8	51.3	38.9	32.0	20.0	15.1	12.0	10.1	8.85	7.03	5.86	3.09
1.65V/cell	101.4	81.4	68.9	54.1	41.2	33.1	20.8	15.7	12.5	10.4	9.16	7.26	6.03	3.19
1.60V/cell	111.6	89.1	74.8	57.8	42.8	34.1	21.3	16.1	12.8	10.7	9.35	7.39	6.16	3.24

Constant Power Discharge (Watts/cell) at 25 °C (77°F)

F.V/Time	10min	15min	20min	30min	45min	1h	2h	3h	4h	5h	6h	8h	10h	20h
1.85V/cell	120.2	102.1	91.5	76.7	59.7	51.2	33.4	25.2	20.7	17.5	15.3	12.4	10.7	5.69
1.80V/cell	135.9	113.1	99.7	82.0	63.9	53.8	35.7	26.9	21.9	18.4	16.2	13.0	11.0	5.88
1.75V/cell	151.9	125.9	109.1	88.4	69.0	58.4	37.0	27.9	22.6	18.8	16.7	13.4	11.3	6.02
1.70V/cell	167.7	137.8	119.5	96.0	74.1	61.6	38.8	29.3	23.5	19.9	17.4	13.9	11.7	6.17
1.65V/cell	178.5	146.4	126.2	100.5	77.7	63.2	40.0	30.4	24.4	20.4	18.0	14.4	12.0	6.35
1.60V/cell	191.9	157.7	135.6	106.5	80.3	64.8	40.9	31.0	24.8	20.8	18.3	14.6	12.2	6.45

Specifications subject to change without notice.



Dimensions

T9 Terminal
Unit: mm [inches]

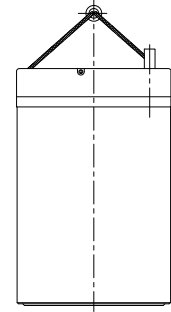
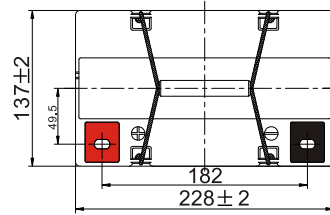
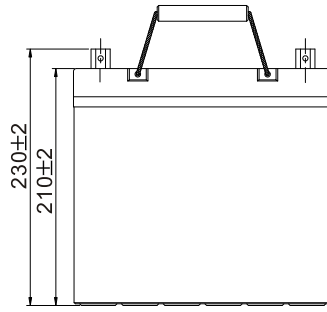
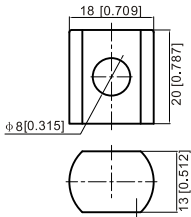

Discharge Characteristics

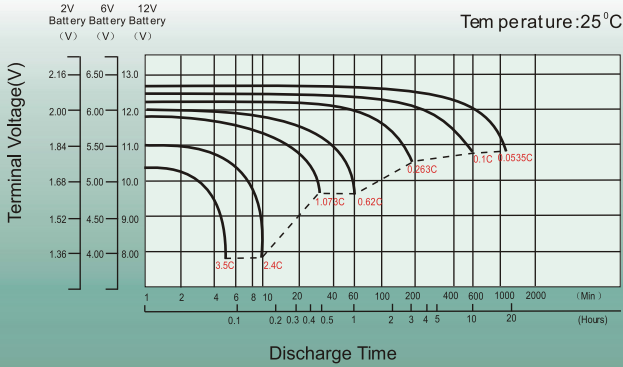

Float Charging Characteristics

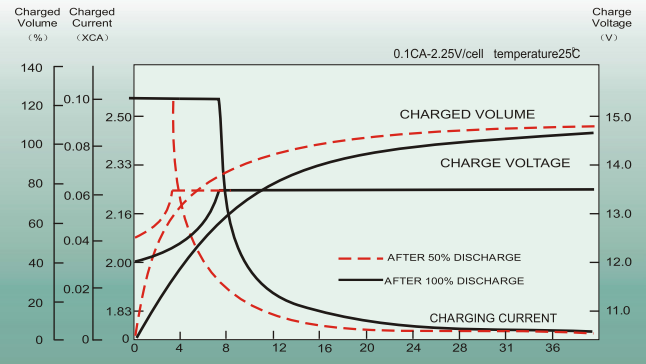

Temperature Effects in Relation to Battery Capacity

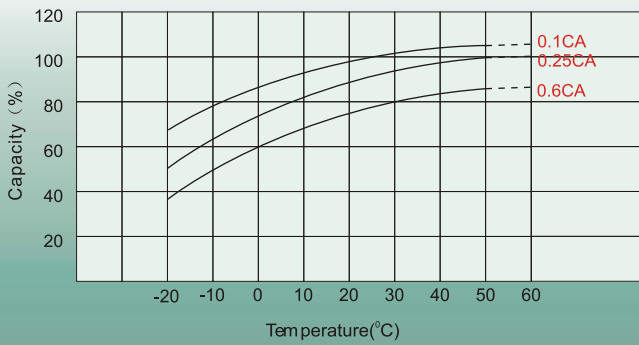

Effect of Temperature on Long Term Float Life

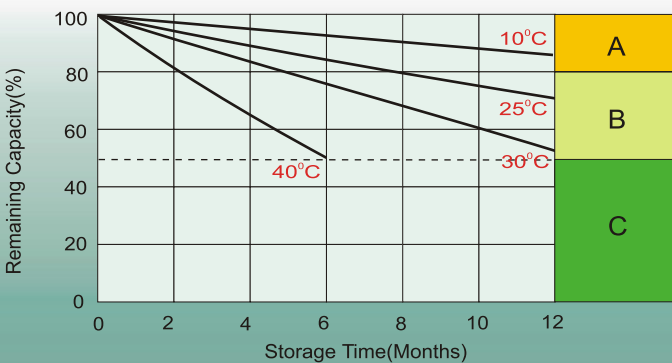
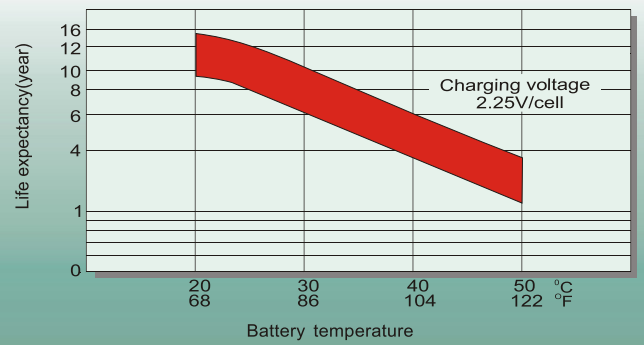

Self Discharge Characteristics

- A** No supplementary charge required
(Carry out supplementary charge before use if 100% capacity is required.)
- B** Supplementary charge required before use. Optional charging way as below:
 1. Charged for above 3 days at limited current 0.25CA and constant voltage 2.25V/cell.
 2. Charged for above 20 hours at limited current 0.25CA and constant voltage 2.45V/cell.
 3. Charged for 8-10 hours at limited current 0.05CA.
- C** Supplementary charge may often fail to recover the capacity.
The battery should never be left standing till this is reached.